

Line Isolation Monitor (LIM) for Single and Three Phase Systems



LIM2000plus™



- Less than 35 microampere LIM hazard current
- No interference with electrical equipment
- Special phase-locking circuitry for ultimate stability and repeatability
- Voltage-free SPDT contact for external alarm
- Provision for remote indicators
- Internal overload protection with automatic reset
- Easy to clean rugged Lexan front foil
- Digital display & analog bar graph
- Automatic self calibration and self check
- Audible alarm volume adjustable via menu

Universal LIM Replacement Program (Retrofit)

With Accessories

- Load Monitoring
- RS485 communication port

Product Description

The Line Isolation Monitor (LIM) measures the total leakage impedance to ground in an isolated (ungrounded) AC power system. Based on this information, the maximum Total Hazard Current (THC) is determined and displayed on a digital display and LED bar graph.

The LIM is available for operation in 50 or 60 Hz systems with AC voltages from 100 to 240V. The supply voltage for the LIM is taken from the system being monitored.

For additional safety, two separate ground connections are provided. Each ground must be wired individually to the Reference Grounding Bus. A break in either connection will cause the LIM to alarm.

The BENDER LIM2000plus™ Series Line Isolation Monitor meets or exceeds all applicable U.S. and Canadian specifications. For use in UL 1047 compliant panel and it complies with **NEC Article 517**, **NFPA 99**, **UL1022** and **CSA Z32.2** and is recognized under UL and CUL file no. E224808.

The LIM2000plus™ easily retrofits the competitors LIMs available in their isolated power panels. Some may simply plug in while others may require the use of simple brackets and/or remote indicators.

Operational Information

Usually, there will be a different impedance between each isolated conductor and ground. Thus, there will be a different current flowing through a person making physical contact between any one of the isolated conductors and ground. The LIM function is to calculate and display the true maximum value of the Total Hazard Current (THC). The BENDER LIM accomplishes this using a patented measurement technique.

The THC is displayed on a seven segment digital display and a bar graph. Normally, the green "SAFE" LED is illuminated, the display shows a low leakage value and the bar graph is in the non-alarm, or safe, green zone. THC levels will increase as additional loads are connected to the system and/or when a line-to-ground fault has suddenly occurred or is slowly developing. There is a visual and audible alarm when the THC exceeds the LIM setting of either 2mA or 5mA. Relay output contacts are available which can be wired into a circuit to trigger an external alarm.

The visual alarm, red "HAZARD" LED remains illuminated for the duration of the fault. The audible alarm can, however, be silenced by pushing the "MUTE" button at any time, at the discretion of personnel in the vicinity of the LIM. When the "MUTE" button is activated, the integral amber LED in the "MUTE" button is illuminated to indicate a muted condition.

Activate the test button to check the LIM operation. Making this test does not add to the hazard current of a system in actual use, nor does the test include the effect of the line-to-ground stray impedance of the system.

The LIM has provisions for connecting one or more Remote Indicators, with or without analog or digital display meter. A Remote Indicator duplicates the LIM audible and visible alarm signals.

The audible alarm sound level adjustment is available via menu.

Load Monitoring Function and RS485 Serial Communication Interface

The load monitoring feature provides the ability to monitor the percentage of load used on the secondary of the isolation transformer by feeding one leg of the secondary wires from the transformer through a current transformer and setting the LIM to the rated secondary amperage of the isolation transformer. The LIM calculates the percentage of load being used. When the isolation transformer approaches 80% of rated power, a flashing yellow LED illuminates. Additionally, there is an audible alarm at 100% load.

The Serial Communication Interface RS485 communication output feature provides the ability to download operational information from the LIM to a Personal Data Assistant (PDA) or personal computer. The information available is the Total Hazard Current, the percentage (%) transformer load, and the alarm status.

Standard Connection Diagram

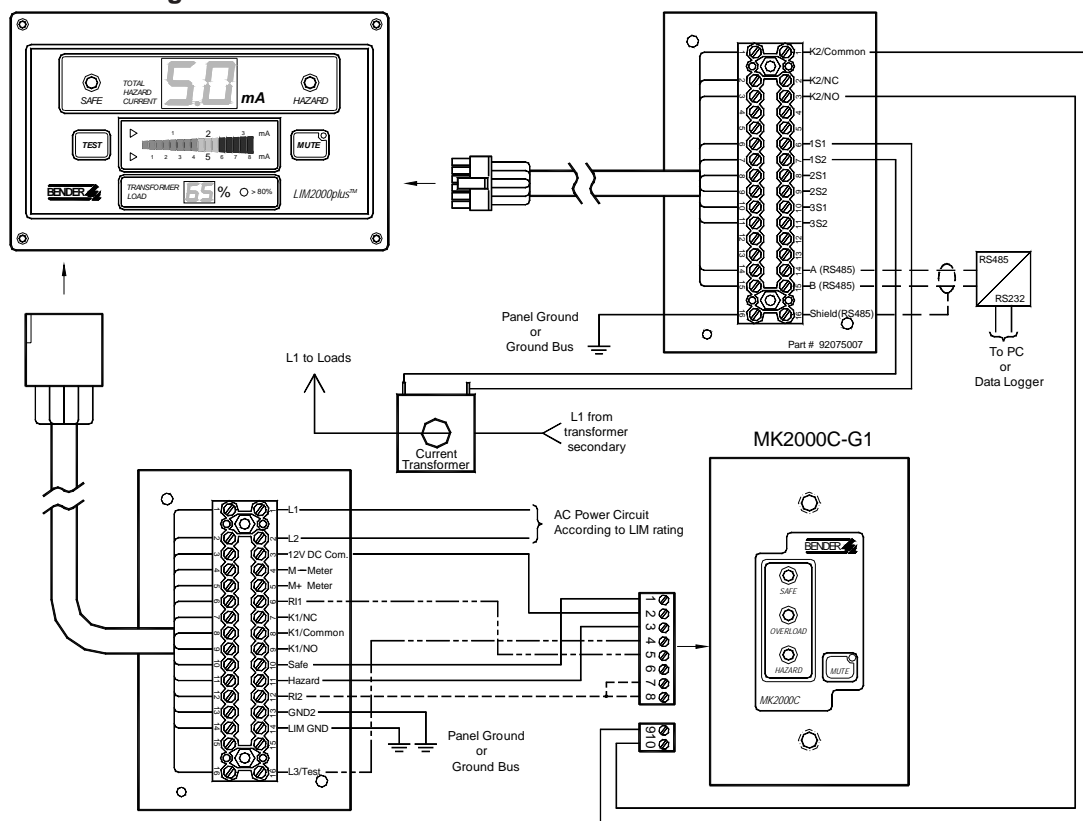

Legend to Standard Connection Diagram

— Connections required in single phase systems using MK2000C-G1 Remote Indicator w/Overload Indicator.

----- Additional connections required in Single Phase systems using MK2000CP-G1 Remote Indicator w/Overload Indicator & "Test" button.

Note: "TEST" function from Remote Indicator is not available for 3 phase systems. L3/"TEST" connection is used as L3 in 3 phase systems.

Overload option requires three (3) Current Transformers, (L1, L2, & L3), in 3 phase systems.

----- Additional connections required for "Systems Muting" option.

----- Connections required for "RS485 Interface".

Other LIM configurations available upon request.

LIM2000plus™ Technical Specification

Insulation class in acc. to UL1022	1850V (1 second)
Dielectric voltage-withstand test	continuous operation
Rated service rating	100V - 120V AC or
Rated mains voltage of V_N	200V - 240V AC 1ph. 200V - 240V AC 3ph.
Frequency range of V_N	50 to 60 Hz (+/- 5%)
Operating range of V_N	85 to 110% of rated voltage
Max. power consumption	22 VA
Max. Measuring current	20 μ A
Monitor hazard current 100 - 120V / 200 - 240V	max. 46 / 78 μ A
Min. internal impedance at 1Ph /3Ph (60 Hz)	3.5 / 3.2 Meg Ω
Nominal response value	5 mA changeable to 2 mA
Response tolerance	1.8 to 2 mA or 4.5 to 5 mA
Response time	< 4 sec.
Response hysteresis	20% of response value
Contacts	one voltage-free SPDT contact one voltage-free SPDT contact for load monitoring
Outputs	12V DC, 200 mA max Remote Indicator output, analog and digital display output
Rated contact voltage	250 V/24V DC
Make capacity	4A AC/ 4A DC
Break capacity at 24 V DC and L/R = 0	4 A
Switching life (240 V AC / 60 Hz)	2 x 10 ⁵ cycles
Operation mode	continuous
LIM overload protection	built-in thermal overload with automatic reset
Operating temperature range	+32°F to +126°F 0°C to +50°C
Storage temperature	-13°F to +158°F -25°C to +70°C
Mounting orientation	any
Connector	15 pin Molex, type 03-09-2152 and 12 pin Molex
Communication Port	RS485 Communication
Weight	approx. 1.2 lb (550 gr.)

Product Information

Line Isolation Monitor (LIM)

Type	Article No.
100-120V, 1Ph**	NA
100-120V, 1Ph, 1CB*	92075002
200-240V, 1Ph**	NA
200-240V, 1Ph, 1CB*	92075004
200-240V, 3Ph, 3CB*	92075005

* LIM with Load Monitoring

** Discontinued Models

Dimension Diagram (inch)

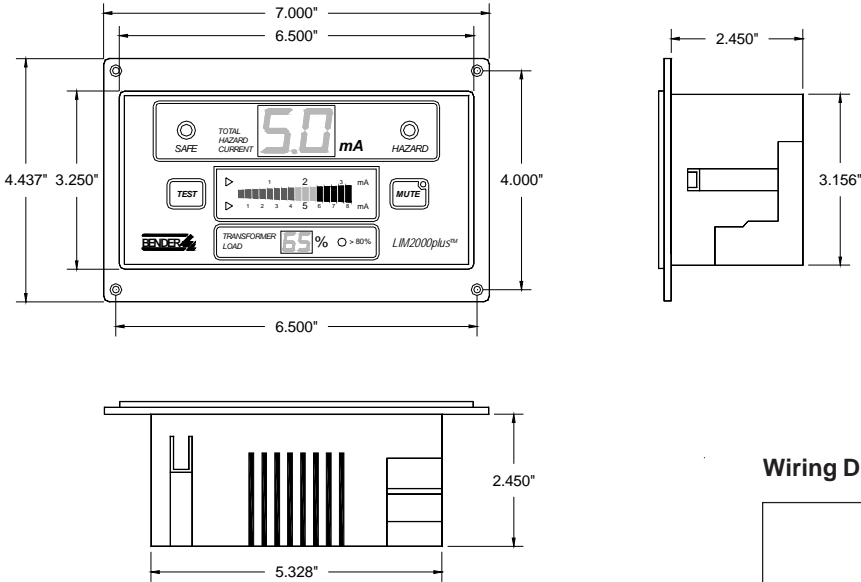

Physical Details

The LIM is less than 2-1/2" deep. Cut-out needed for new flush panel mounting is 7" x 4-7/16" (+0, -1/32"). Cut-out needed for surface panel mounting is 5-3/8" x 3-1/4" (+0, -1/32"). Mounting holes are on 4" and 6-1/2" centers.

A 15-pin and 12-pin female Molex connectors are built into the back of the LIM2000plus™. Each connector plate assembly has a 15" cable and either a 15-pin or 12-pin male Molex connector available to facilitate field wiring.

Legend to Connector Plate Wiring Diagram

- L1, L2: To secondary of Isolation Transformer. Recommended in-line fuses
- 12V DC Com.: Common connection of external Remote Indicator
- Safe: "Safe" light connection of external Remote Indicator
- Hazard: "Hazard" light connection of external Remote Indicator
- M-, M+: External mA meter (400 μA)
- RI1: Test button source
- RI2: Local and system muting from LIM and Remote Indicator
- K1/NC: NC contact of the alarm relay K1
- K1/Common: Common contact of the alarm relay K1
- K1/NO: NO contact of the alarm relay K1
- GND2, LIM GND: Ground connections, if one is interrupted LIM will alarm
- L3/Test: Remote "Test" function or connection L3 in three phase systems

LIM2000plus™ Connector Plate

Cable length	20" (0.5m)
Terminal Strip	16 terminals
Connector	15 pin Molex
Max. conductor size	12 AWG
Mounting orientation	by screws
Weight	approx. 0.44 lb

Wiring Diagram

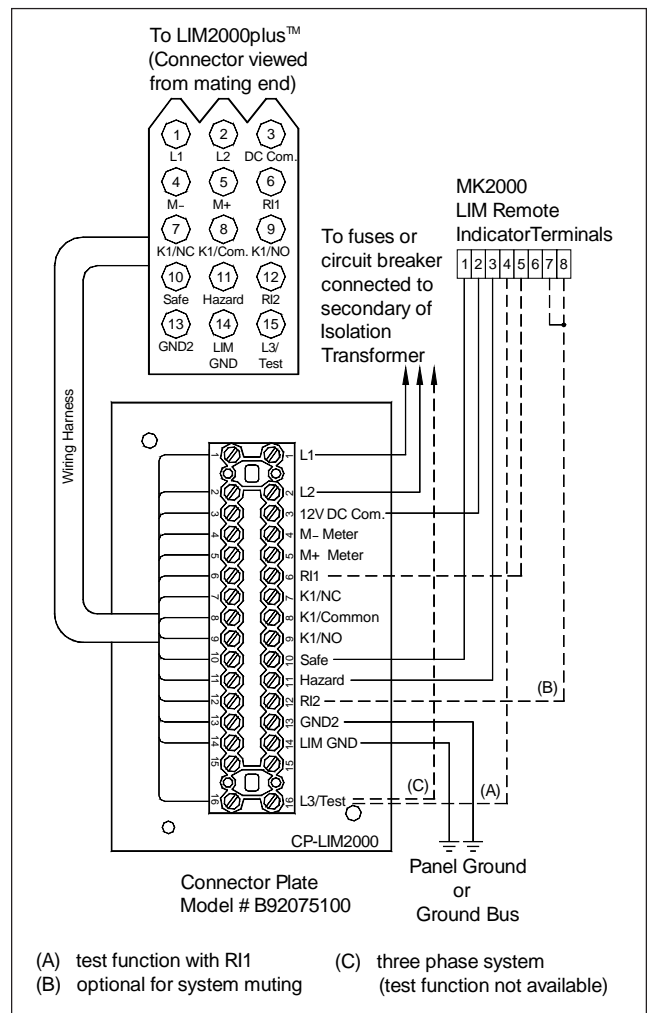

- (A) test function with RI1
- (B) optional for system muting
- (C) three phase system (test function not available)

Wiring Diagram

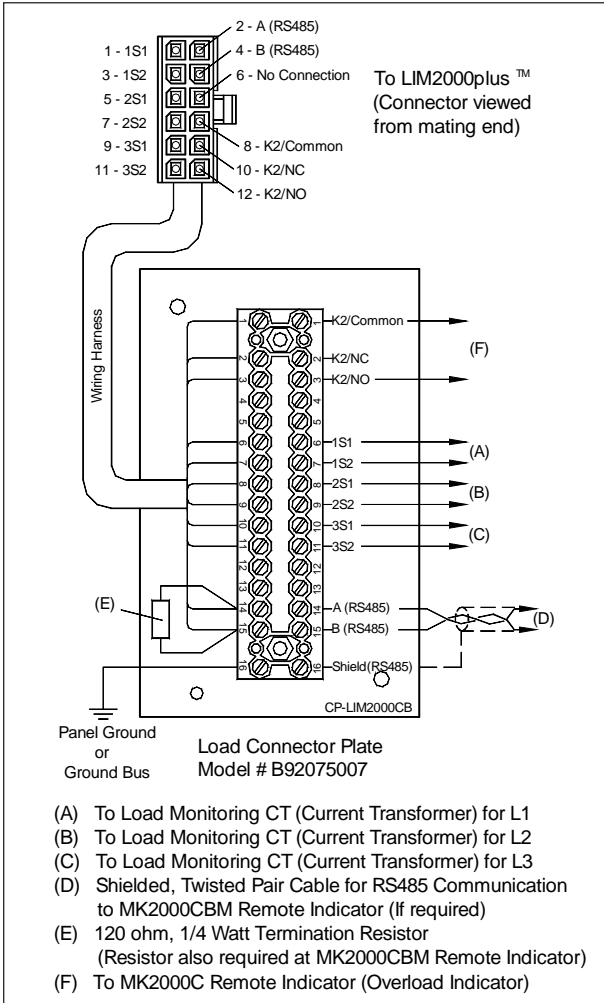

Product Information

LIM Connector Plates

Type	Article No.
CP-LIM2000	92075100
CP-LIM2000CB	92075007

Legend to Load Monitoring & RS485 Connector Plate

- K2 / Common: Overload Indicator on MK2000C-G1
- K2 / NC : NC contact of the alarm relay K2
- K2 / NO : Overload Indicator on MK2000C-G1
- 1S1, 1S2, To Current Transformer (CT) Connections (1Phase)
- 2S1, 2S2, To Current Transformer (CT) Connections (3 Phase)
- 3S1, 3S2: To Current Transformer (CT) Connections (3 Phase)
- A, B, Shield: RS485 Communication

LIM2000plus™ Auxiliary Connector Plate

Cable length	20" (0.5m)
Terminal Strip	16 terminals
Connector	12 pin Molex
Max. conductor size	12 AWG
Mounting orientation	by screws
Weight	approx. 0.44 lb

Load Monitoring Current Transformer

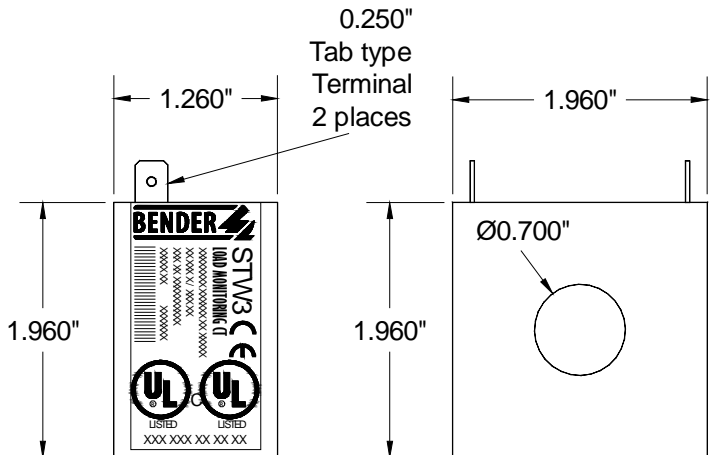

Specifications and other data subject to change without notice.

Product Information

Load Monitoring Current Transformer

Type	Article No.
STW3 (up to 100A)	98021000
STW4 (over 100A)	98021001

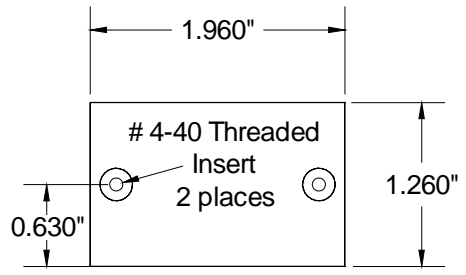

BOTTOM VIEW

Display

1. Amber Total Hazard Current Set Point LEDs
Indicates the 5mA (2mA Canada) "THC" set point
2. "TEST" button
Checks functions of the LIM
3. Green "SAFE" LED
Illuminated unless LIM is in alarm mode
4. LED Analog Bar Graph
Displays Total Hazard Current
5. THC Digital Display
Displays Total Hazard Current
6. Red "HAZARD" LED
Indicates "THC" alarm
7. "MUTE" button w/integral amber LED
Silences alarm buzzer
8. Flashing amber Transformer Load Digital Display
Indicates transformer load over 80%
(with accessories)
9. Transformer Load Digital Display
Displays transformer load in percentage
(with accessories)

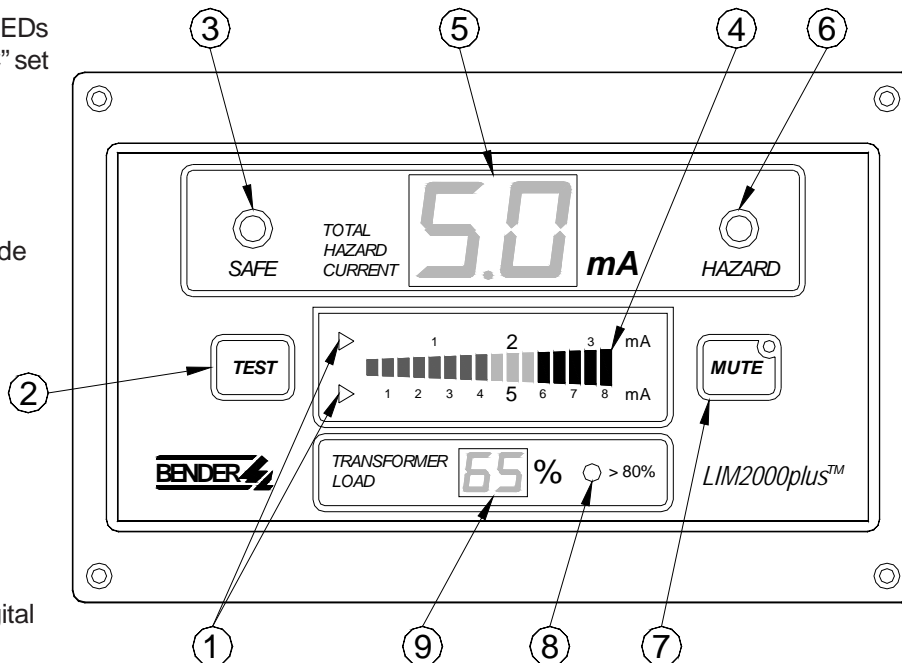

Error-Codes Listing

ER	1.0	Ground error LIM-GND or GND2 interrupted
ER	2.0	A/D converter calibration failed; hardware malfunction
ER	3.0	Measuring circuit test failure; hardware malfunction
ER	4.0	Actual system voltage is above LIM calibrated voltage
ER	4.5	Actual signal voltage is above LIM calibrated voltage
ER	5.0	LIM hardware malfunction
ER	6.0	Program sequence interrupted; EMI interference
ER	6.5	Program sequence interrupted; stack point indication too high
ER	ER	Error in the current measuring circuitry

Codes alternate between ER and number i.e. ER and 1.0 except when code shown for error only, then ER stays solid.



BENDER MEDICAL PRODUCTS

700 Fox Chase

Coatesville, PA 19320

Phone: 800-356-4266

610-383-9200

Fax: 610-383-7100

E-mail: medical@bender.org

Website: www.isotrolsystems.com

Standards

The BENDER LIM2000plus™ Series Line Isolation Monitor meets or exceeds all applicable U.S. and Canadian specifications. It complies with **NEC Article 517, NFPA 99, UL1022, CSA Z32.2** and is UL and CUL recognized.

Safety Instructions



Electrical equipment shall only be installed by qualified personnel in consideration of the applicable safety regulations.